

## Oil Sampling

To obtain a representative sample the following considerations should be addressed.

1. The sample should be taken from the centre 1/3 rd of the pipeline
2. Upstream of the sampler, the product should be mixed preferable with a properly sized static mixer. That will give a homogeneous mix of the product .
3. Two types of systems are normally used.
  - a) Insertion sampler. Collects the sample directly from within the pipeline.
  - b) Bypass system where the sample is collected outside the pipeline. This requires a pitot tube to collect the sample and a pump in the bypass line that will maintain the bypass line flow to that of the flow in the pipeline
4. If the sample is to be transported, a sample cylinder or container that will maintain the sample in the same condition as in the pipeline, should be used.
5. If the collection container is permanently fixed, it should have a circulating pump to mix the product before samples are drawn off.
6. To actuate the sampler a conditioned pulse will be required that actuates the sampler proportional to the flow in the pipeline.
7. Tubing from the exit of the sampler to the collection device should slope downwards with no reservoir points.
8. An insertion sampler should be mounted vertically or at any point to horizontally.

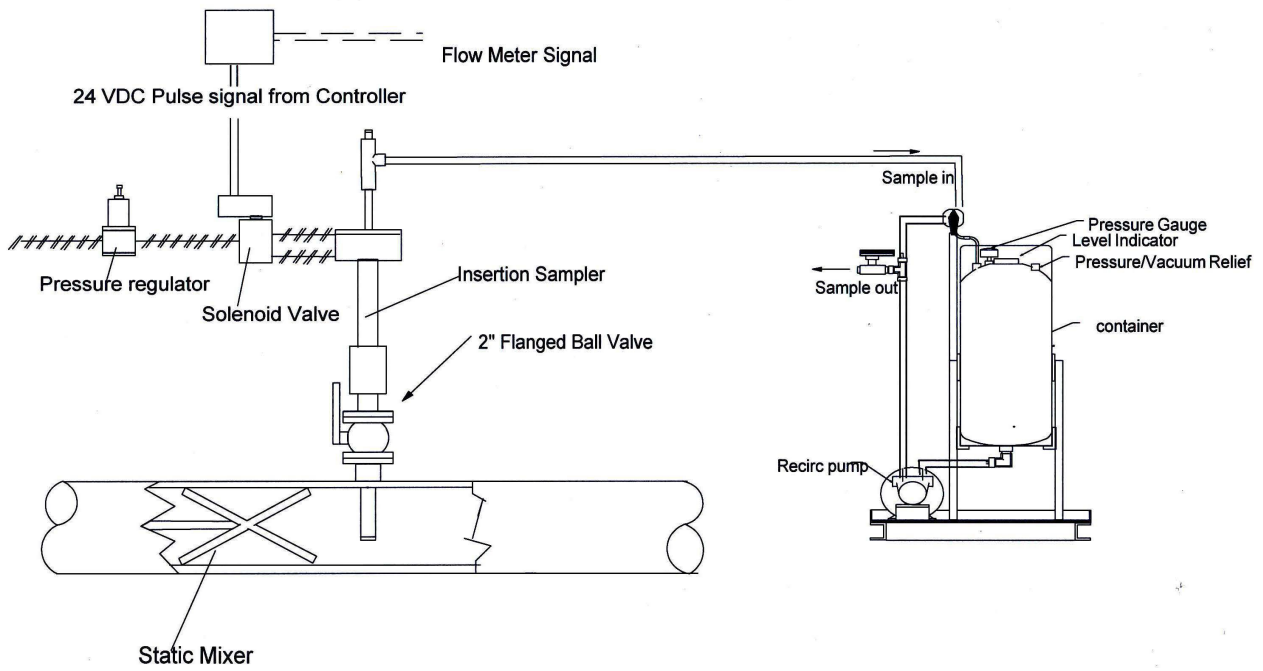

Typical Crude Oil Sampling System