

BP-HF251 Datasheet

HIGH-FLOW BACK PRESSURE REGULATOR

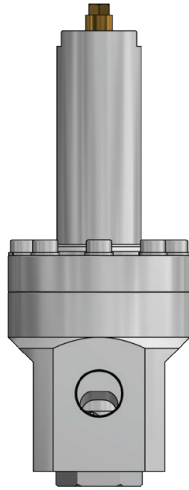

Gas
 Liquid
 |
 Diaphragm
 Piston
 |
 Max Rating: 300 bar (4,350 psi)
 |
 Max Inlet Control: 200 bar (2,900 psi)
 |
 Cv 7.0



INTRODUCING THE BP-HF251...

The BP-HF251 is a piston-sensed high-flow back pressure regulator for gas or liquid applications. The liquid version includes a Tecasint® seat, whilst the gas version features PEEK™ seating.

With a **balanced main valve** as standard it provides stable control with a high level of accuracy under varying inlet pressures. Plus, its high flow coefficient ensures the BP-HF251 can also cope with higher flow rates.

SPECIFICATION

Max. Rating	300 bar (4,350 psi)
Max. Inlet Control	Up to 200 bar (2,900 psi)
Design Proof Pressure	150% max. working pressure
Seat Leakage	In accordance with ANSI/FCI 70-3
Weight	12kg (26.5lbs)

* Pressure regulator rating may be limited by connection type, Cv and/or seat material

STANDARD MATERIALS OF CONSTRUCTION

PART	MATERIALS
Body and Bonnet	AISI 316/316L Stainless Steel (UNS S31600/S31603)
Main Valve Pin	AISI 316/316L Stainless Steel (UNS S31600/S31603)
Soft Seat	Tecasint® or PEEK™
Valve Spring	AISI 302 S26 Stainless Steel
Piston	AISI 316/316L Stainless Steel (UNS S31600/S31603)
O-Rings	NBR or FKM/FPM
Loading Spring	Alloy Spring Steel

FEATURES AND BENEFITS

1 PISTON SENSING ELEMENT

Perfect for use in challenging conditions.

2 SUITABLE FOR GAS OR LIQUID APPLICATIONS

Versatile usage across a range of media-types.

3 HIGH FLOW COEFFICIENT

Cv 7.0 for high-flow capabilities.

4 BALANCED MAIN VALVE DESIGN

Offers seat load reduction which extends time before routine service is required.

Product availability and specifications contained herein are subject to change without notice. Consult local distributor or factory for potential revisions and/or service related issues. Pressure Tech Ltd support with product selection recommendations only - it is the users responsibility to ensure the product is suitable for their specific application requirements.



DESIGNED AND BUILT IN THE UK

PRESSURE TECH LTD

Unit 24, Graphite Way, Hadfield, Glossop, Derbyshire, UK, SK13 1QH
 T +44 (0)1457 899 307
 E sales@pressure-tech.com
 W www.pressure-tech.com

200819

PAGE:
1 OF 4

BP-HF251 Datasheet

HIGH-FLOW BACK PRESSURE REGULATOR



Gas
 Liquid
 Diaphragm
 Piston
 Max Rating: 300 bar (4,350 psi)
 Max Inlet Control: 200 bar (2,900 psi)
 Cv 7.0

DRAWINGS AND INSTALLATION DIMENSIONS

Dimensions shown for 1" NPT option - please contact the office for additional connection options.

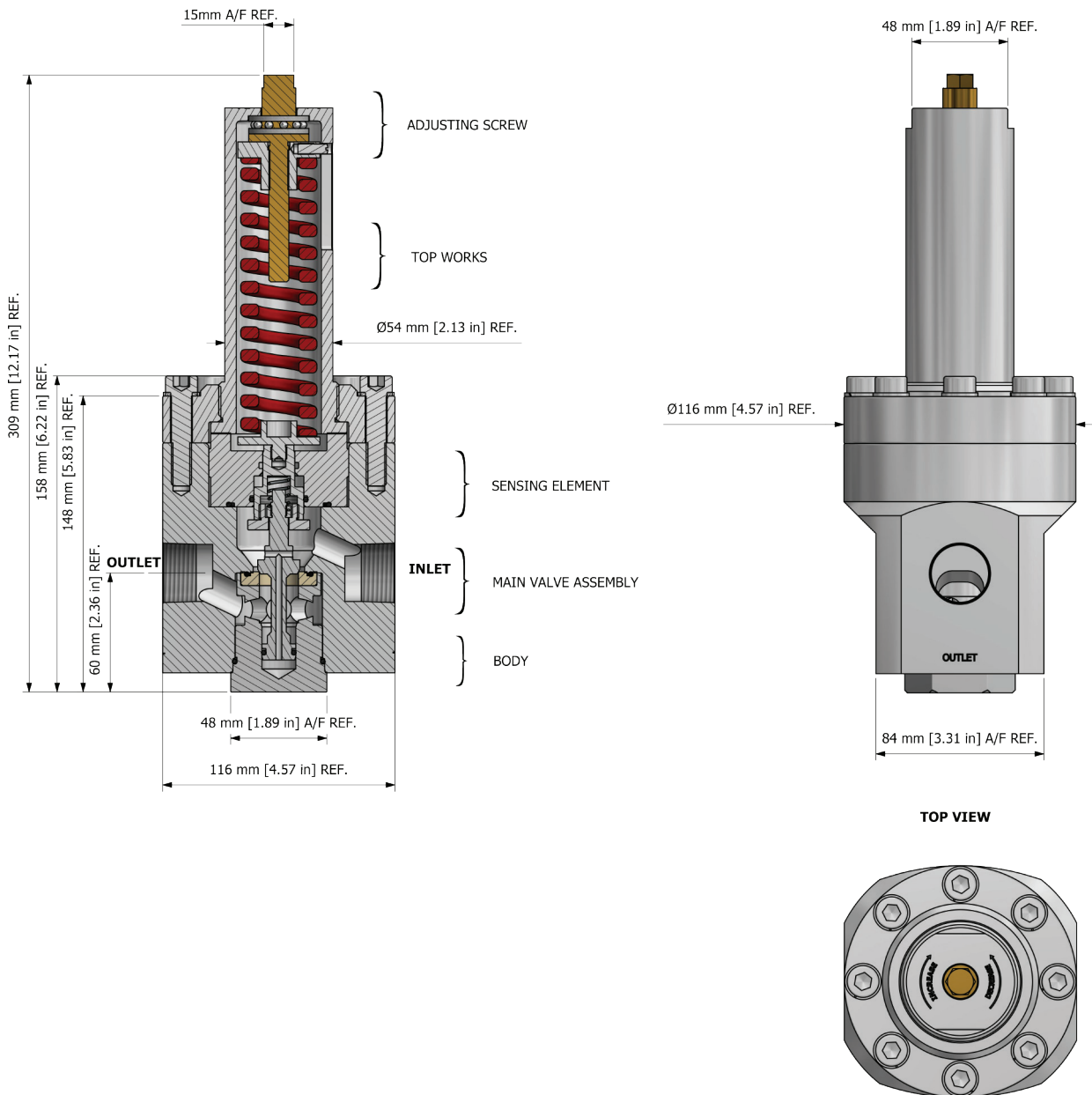

Note:
All gauge ports are 1/4" NPT as standard.

Product availability and specifications contained herein are subject to change without notice. Consult local distributor or factory for potential revisions and/or service related issues. Pressure Tech Ltd support with product selection recommendations only - it is the users responsibility to ensure the product is suitable for their specific application requirements.



DESIGNED AND BUILT IN THE UK

PRESSURE TECH LTD
 Unit 24, Graphite Way, Hadfield, Glossop, Derbyshire, UK, SK13 1QH
 T +44 (0)1457 899 307
 E sales@pressure-tech.com
 W www.pressure-tech.com

200819

PAGE:
2 OF 4

BP-HF251 Datasheet

HIGH-FLOW BACK PRESSURE REGULATOR



● Gas ● Liquid | ● Diaphragm ● Piston | Max Rating: 300 bar (4,350 psi) | Max Inlet Control: 200 bar (2,900 psi) | Cv 7.0

FLOW CURVE

Please contact the office for further information.

PORTING CONFIGURATIONS

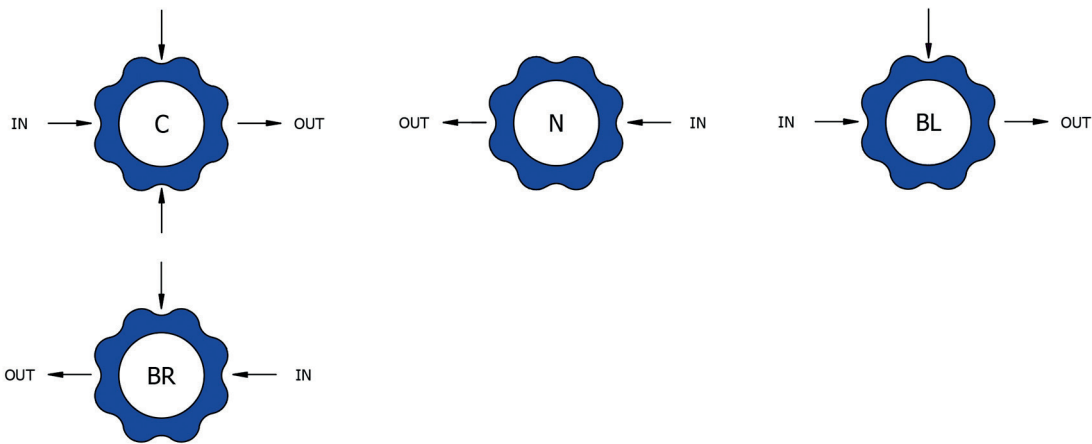

Note:

Additional porting configurations are available - please contact the office for further information.

Product availability and specifications contained herein are subject to change without notice. Consult local distributor or factory for potential revisions and/or service related issues. Pressure Tech Ltd support with product selection recommendations only - it is the users responsibility to ensure the product is suitable for their specific application requirements.



DESIGNED AND BUILT IN THE UK



PRESSURE TECH LTD

Unit 24, Graphite Way, Hadfield, Glossop, Derbyshire, UK, SK13 1QH
T +44 (0)1457 899 307
E sales@pressure-tech.com
W www.pressure-tech.com

200819

PAGE:
3 OF 4

BP-HF251 Datasheet

HIGH-FLOW BACK PRESSURE REGULATOR



Gas
 Liquid
 Diaphragm
 Piston
 Max Rating: 300 bar (4,350 psi)
 Max Inlet Control: 200 bar (2,900 psi)
 Cv 7.0

ORDERING INFORMATION

To build a Pressure Tech part number, simply combine the characters identified below in sequence:

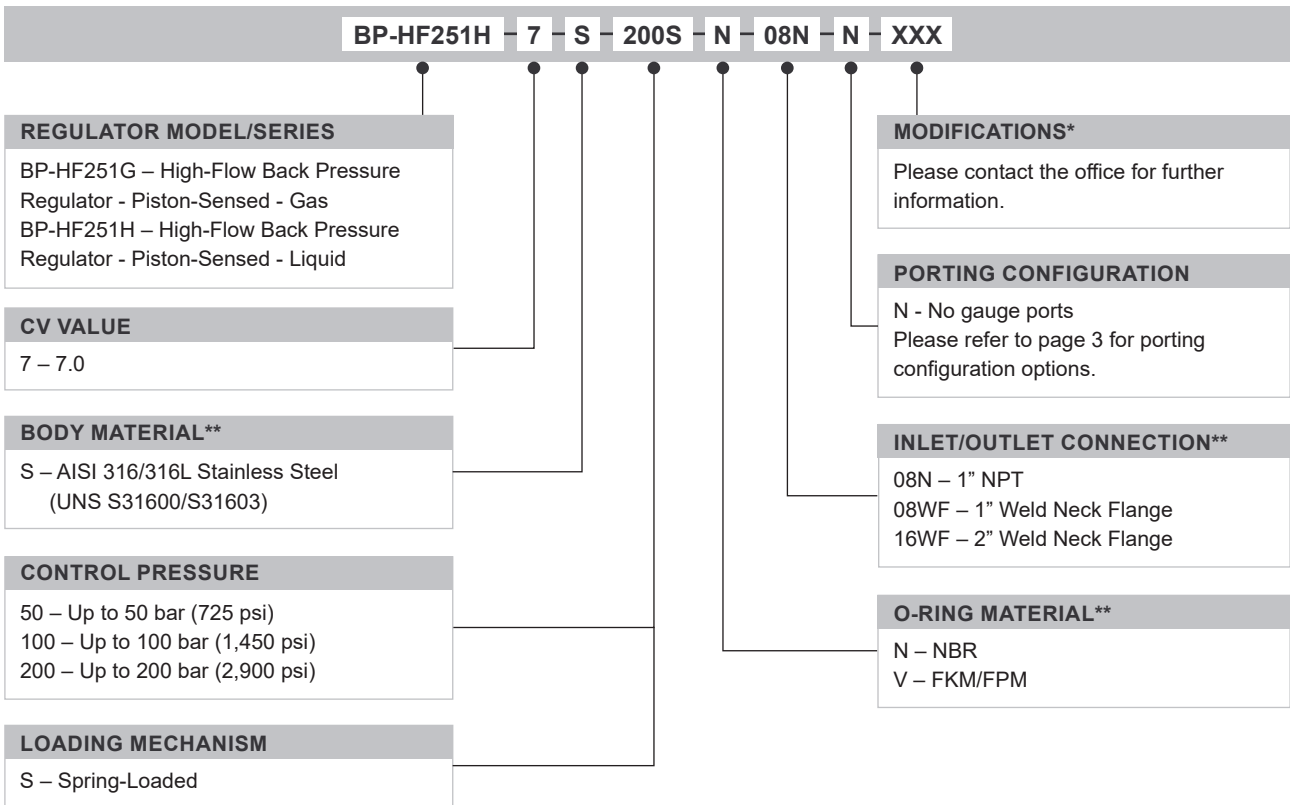

OPTIONAL EXTRAS		
	PART NUMBER	DESCRIPTION
Service Kit	SRK-BPHF251...	Various options available

Note:
Ancillary equipment also available

TRADEMARK: PEEK™ is a trademark of Victrex PLC
 Tecasin® is a registered trademark of Ensinger GmbH

* Where applicable
 ** Other materials/connections may be available - please contact the office

Product availability and specifications contained herein are subject to change without notice. Consult local distributor or factory for potential revisions and/or service related issues.
 Pressure Tech Ltd support with product selection recommendations only - it is the users responsibility to ensure the product is suitable for their specific application requirements.



DESIGNED AND BUILT IN THE UK

Haldatec

Phone: +61 3 9872 5822 Email: sales@haldatec.com.au Website: www.haldatec.com.au

200819

PAGE:
4 OF 4