

LF540 Datasheet

LOW-FLOW PRESSURE REGULATOR



Gas
 Liquid
 Diaphragm
 Piston
 Self-Venting
 Non-Venting
 Max Inlet: 690 bar (10,000 psi)
 Max Outlet: 414 bar (6,000 psi)
 Cv 0.1



INTRODUCING THE LF540...

The LF540 is a compact and economical piston-sensed, low-flow regulator with precision machined sensing elements to allow fine pressure control up to 414 bar (6,000 psi).

Its load bearings and large handwheel offer low torque adjustment, and the LF540 can be supplied as non-venting or self-venting, non-captured (on gas only).

Please Note: Cv 0.3 is only available as non-venting.

SPECIFICATION

Max. Rated Inlet Pressure	690 bar (10,000 psi)
Outlet Ranges	Up to 414 bar (6,000 psi)
Design Proof Pressure	150% max. working pressure
Seat Leakage	In accordance with ANSI/FCI 70-3
Weight	2.3kg (5lbs)

* Pressure regulator rating may be limited by connection type, Cv and/or seat material

STANDARD MATERIALS OF CONSTRUCTION

PART	MATERIALS
Body and Bonnet	AISI 316/316L Stainless Steel (UNS S31600/S31603)
Main Valve Pin	AISI 316/316L Stainless Steel (UNS S31600/S31603)
Soft Seat	PEEK™
Valve Spring	AISI 316 S42 Stainless Steel
Piston	AISI 316/316L Stainless Steel (UNS S31600/S31603)
Handwheel	Nylon
O-Rings	FKM/FPM
Loading Spring	Silicon Chrome Wire
Filter	40 Microns

FEATURES AND BENEFITS

1 PISTON SENSING ELEMENT

Perfect for use in challenging conditions.

2 PRECISION MACHINED SENSING ELEMENT

For accurate pressure control.

3 COMPACT DESIGN

Perfect for when installation space is restricted.

4 SELF-VENTING OR NON-VENTING

Versatile use for a wide range of applications.

Product availability and specifications contained herein are subject to change without notice. Consult local distributor or factory for potential revisions and/or service related issues. Pressure Tech Ltd support with product selection recommendations only - it is the users responsibility to ensure the product is suitable for their specific application requirements.



DESIGNED AND BUILT IN THE UK

PRESSURE TECH LTD
 Unit 24, Graphite Way, Hadfield, Glossop, Derbyshire, UK, SK13 1QH
 T +44 (0)1457 899 307
 E sales@pressure-tech.com
 W www.pressure-tech.com

280920

PAGE:
1 OF 4

LF540 Datasheet

LOW-FLOW PRESSURE REGULATOR



Gas
 Liquid
 Diaphragm
 Piston
 Self-Venting
 Non-Venting
 Max Inlet: 690 bar (10,000 psi)
 Max Outlet: 414 bar (6,000 psi)
 Cv 0.1

DRAWINGS AND INSTALLATION DIMENSIONS

Dimensions shown for 1/4" NPT option - please contact the office for additional connections options.

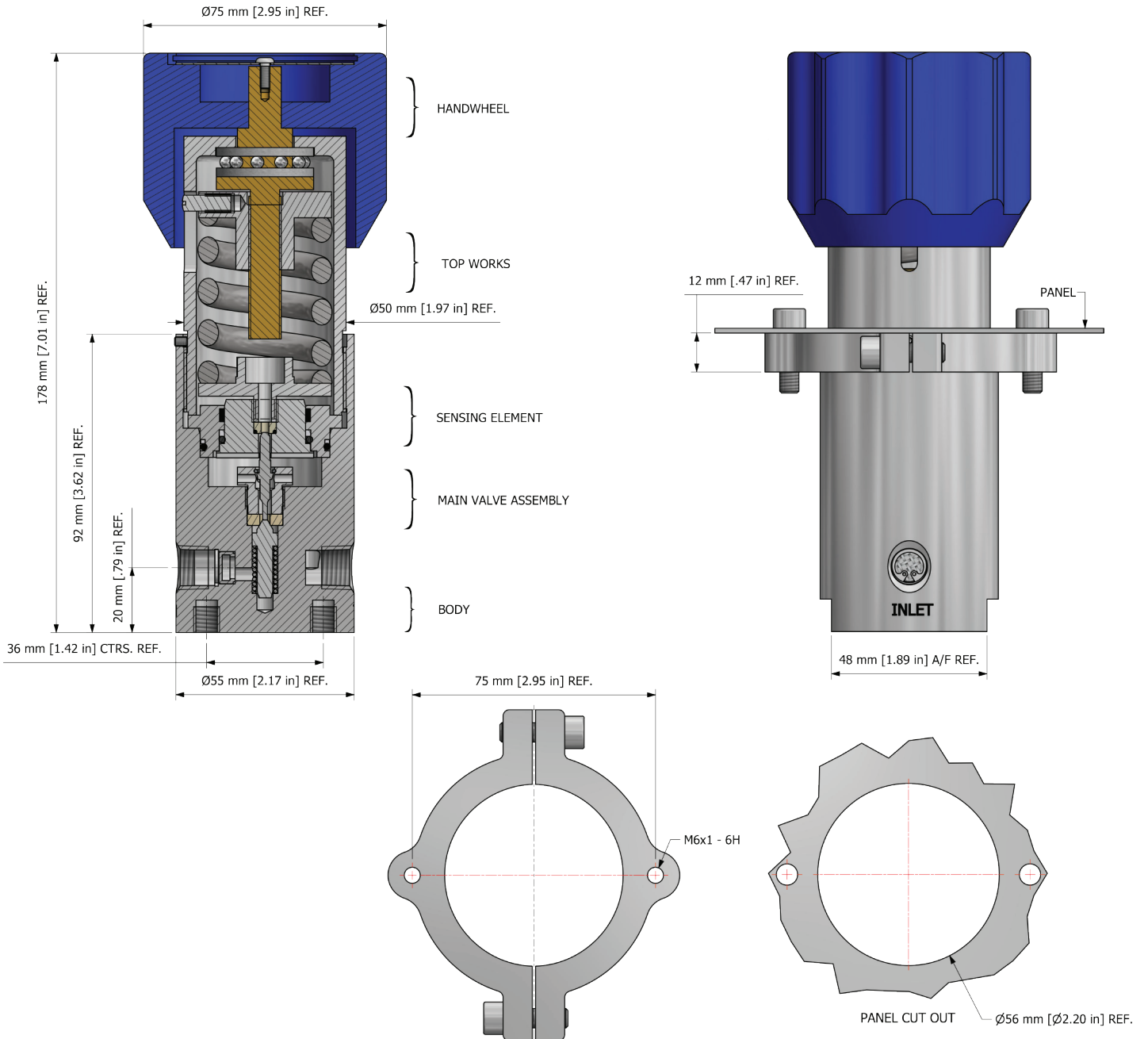

PT-C-061-005-RING (STAINLESS STEEL)
 PT-C-061-005-001-RING (ALUMINIUM)
 PANEL MOUNT RING

Note:
All gauge ports are 1/4" NPT as standard.

Product availability and specifications contained herein are subject to change without notice. Consult local distributor or factory for potential revisions and/or service related issues. Pressure Tech Ltd support with product selection recommendations only - it is the users responsibility to ensure the product is suitable for their specific application requirements.



DESIGNED AND BUILT IN THE UK

PRESSURE TECH LTD
 Unit 24, Graphite Way, Hadfield, Glossop, Derbyshire, UK, SK13 1QH
 T +44 (0)1457 899 307
 E sales@pressure-tech.com
 W www.pressure-tech.com

280920

PAGE:
2 OF 4

LF540 Datasheet

LOW-FLOW PRESSURE REGULATOR



Gas
 Liquid
 Diaphragm
 Piston
 Self-Venting
 Non-Venting
 Max Inlet: 690 bar (10,000 psi)
 Max Outlet: 414 bar (6,000 psi)
 Cv 0.1

FLOW CURVE

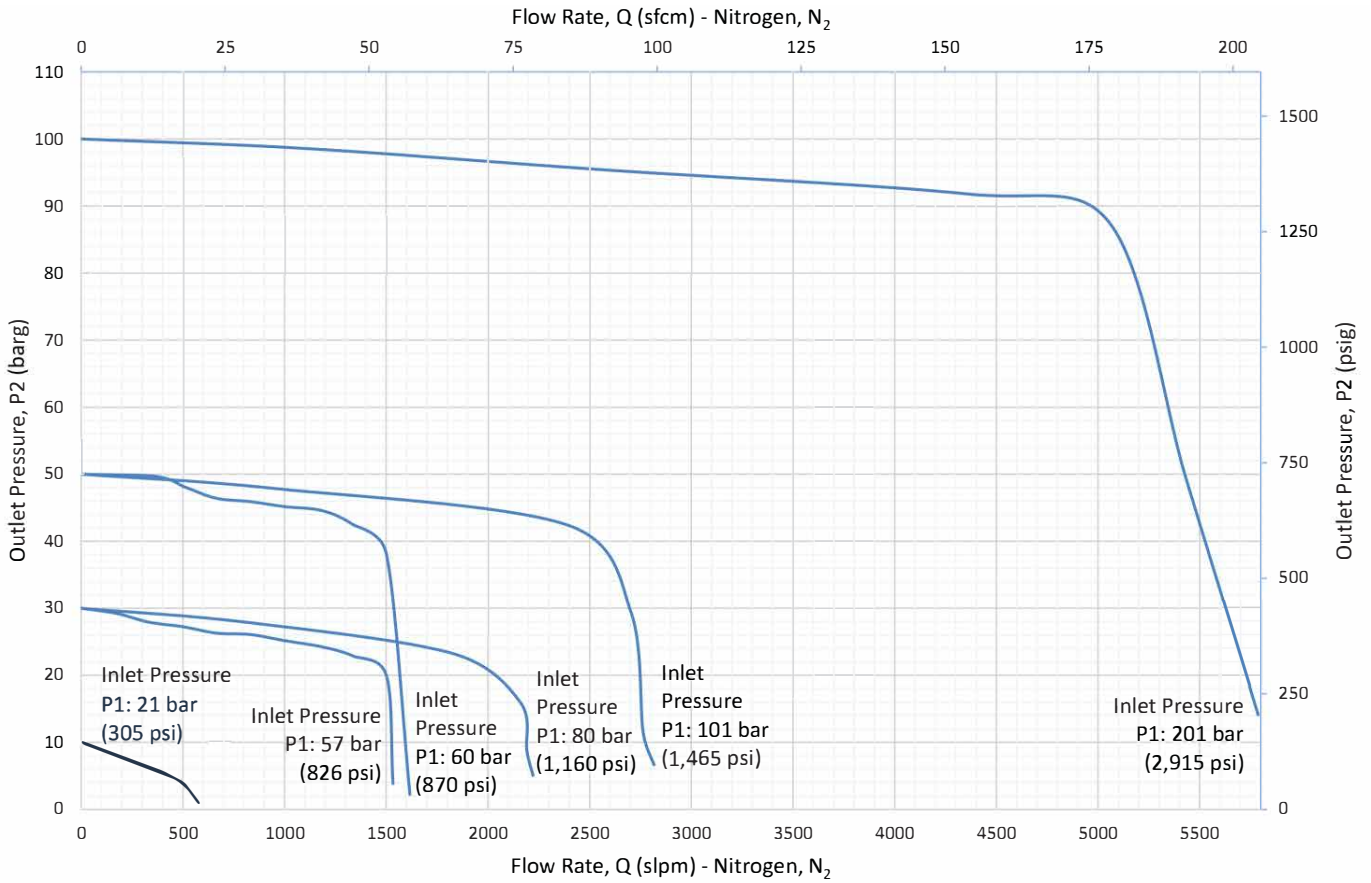

PORTING CONFIGURATIONS

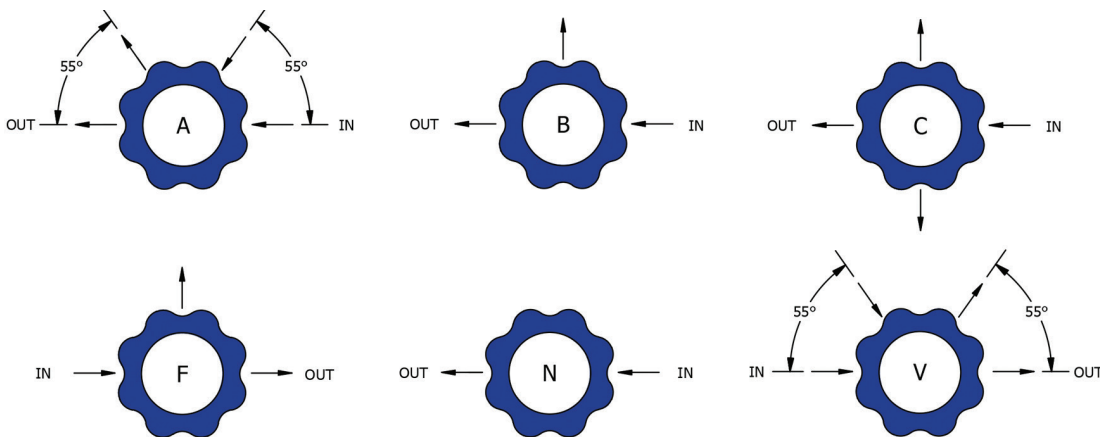

Note:

Additional porting configurations are available - please contact the office for further information.

Product availability and specifications contained herein are subject to change without notice. Consult local distributor or factory for potential revisions and/or service related issues. Pressure Tech Ltd support with product selection recommendations only - it is the users responsibility to ensure the product is suitable for their specific application requirements.



DESIGNED AND BUILT IN THE UK

PRESSURE TECH LTD

Unit 24, Graphite Way, Hadfield, Glossop, Derbyshire, UK, SK13 1QH
 T +44 (0)1457 899 307
 E sales@pressure-tech.com
 W www.pressure-tech.com

280920

PAGE:
3 OF 4

LF540 Datasheet

LOW-FLOW PRESSURE REGULATOR



Gas
 Liquid
 Diaphragm
 Piston
 Self-Venting
 Non-Venting
 Max Inlet: 690 bar (10,000 psi)
 Max Outlet: 414 bar (6,000 psi)
 Cv 0.1

ORDERING INFORMATION

To build a Pressure Tech part number, simply combine the characters identified below in sequence:

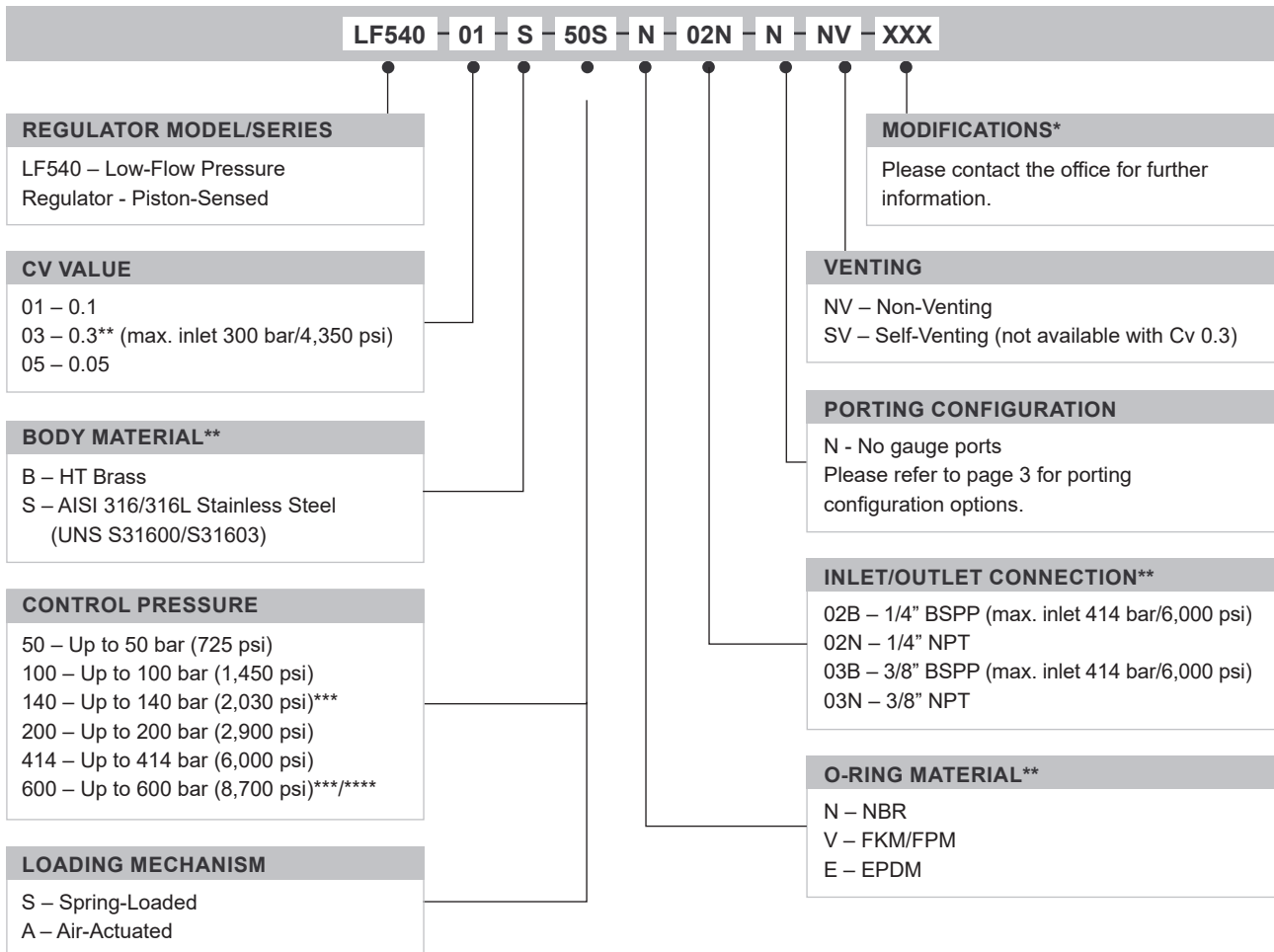

OPTIONAL EXTRAS		
	PART NUMBER	DESCRIPTION
Service Kit	SRK-LF540...	Various options available
Panel Mounting Ring	PT-C-061-005-RING	Stainless Steel panel mount ring
Panel Mounting Ring	PT-C-061-005-001-RING	Aluminium panel mount ring

Note:
Ancillary equipment also available

TRADEMARKS: PEEK™ is a trademark of Victrex PLC

* Where applicable
 ** Other connections/materials may be available - please contact the office
 *** Air-loaded only
 **** Increased supply pressure

Product availability and specifications contained herein are subject to change without notice. Consult local distributor or factory for potential revisions and/or service related issues. Pressure Tech Ltd support with product selection recommendations only - it is the users responsibility to ensure the product is suitable for their specific application requirements.



DESIGNED AND BUILT IN THE UK

Haldatec

Phone: +61 3 9872 5822 Email: sales@haldatec.com.au Website: www.haldatec.com.au

280920

PAGE:
4 OF 4