

5-VALVE MANIFOLD - POWER STYLE

3/16" Bore 5-Valve Power Style Manifold

Phoenix offers this 5-valve globe pattern manifold for 6,000 psi service. The manifold is designed to function as a 3-valve manifold with the addition of two vent/calibration valves, which allow venting and draining of the transmitter for safe disposal of process media. The additional connections can also be used for field calibration of a transmitter.

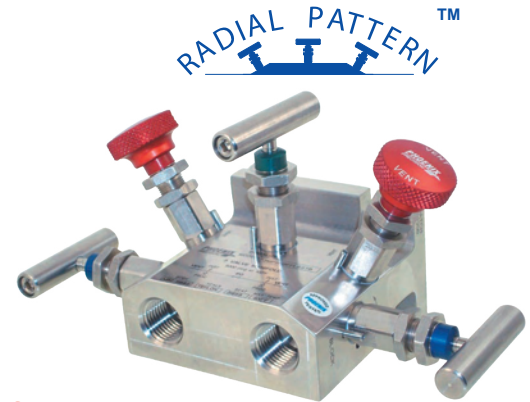

Standard Features

Hydrotested at 150% of rated pressure (shell test). Nitrogen gas tested to 2000 psi.



Seat tightness (zero leakage) verified to 110% of rated pressure. Nitrogen gas tested to 2000 psi.

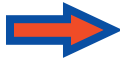

Packing below stem threads

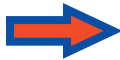

Metal body-to-bonnet seals are in compression, not tension

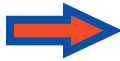

Stem threads are rolled, not cut



8 RMS stem finish

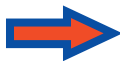

V-Style Teflon™ packing

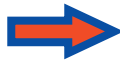

True globe pattern valve

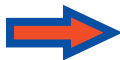

Pressure component materials sourced from the US, Canada or Europe



Benefits

Complies with ASME B31.1 & B31.3 shell testing procedures as standard. Ensures structural integrity of valve.

Complies with ASME B31.1 & B31.3 seat testing procedures as standard. Ensures zero leakage at seats for proper calibration.

Prevents corrosion of critical stem threads

Mitigates risk of stress cracking

Higher quality stem for longer service life

Extended packing life

30-40% less operational torque and less frequent packing adjustments than traditional Teflon™ packed valves.

Extended packing life

Reliable material traceability. MTR's provided with every order for pressure containing components.

Top View of Power Manifold

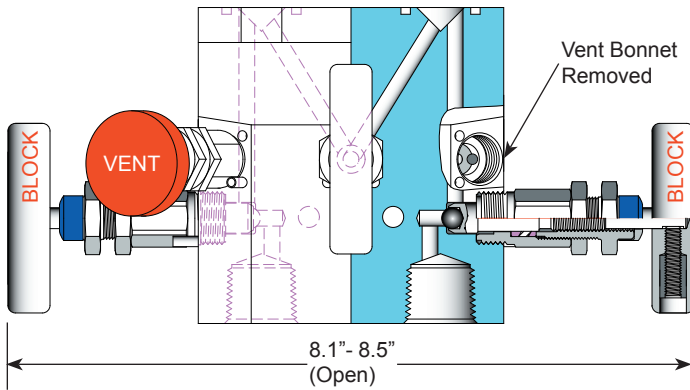

Bottom View of Power Manifold

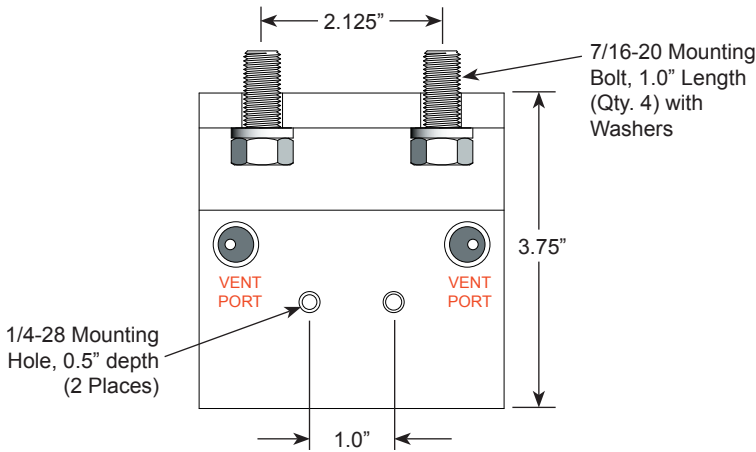

Section View with Color Coded Bonnets

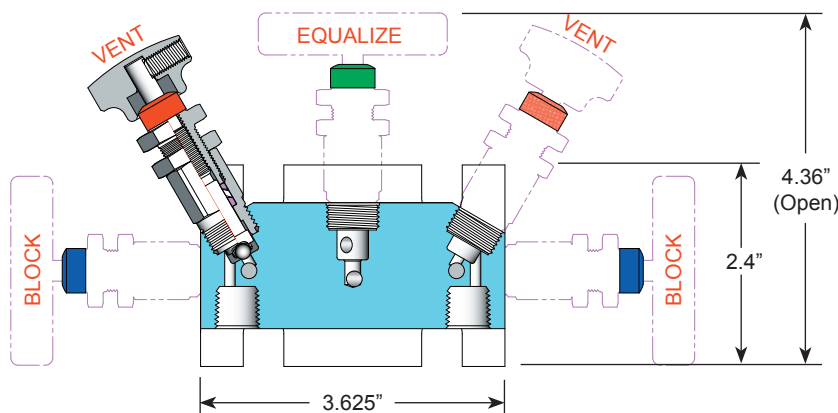

Specifications:

Type: **P3MP5H**, 5-valve Power Style Manifold, Globe Pattern
 Rating: Up to 6000 psi @ 100°F (41370 kPa @ 38°C)
 Stem: Needle tip or Ball tip
 Packing: Teflon™ or Grafoil™
 Seat: Integral
 Handle: Removable
 Bore Size: 3/16" (Primary, Equalize) 1/8" (Vent)
 Inlet Connections: FNPT
 Outlet Connections: Flange
 Bonnet Lock: Pin or Plate
 Body Stock: 3.625" x 3.750" x 2.4" x 1.25"
 Weight: 5.8 - 6.1 lbs
 Special Service: O₂ or CL cleaning available*

*Other specifications or services may be available.

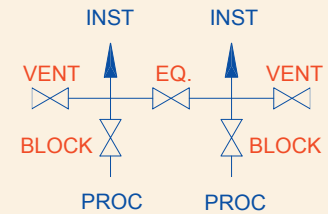

Color Coding of Bonnets:

Block Bonnet: Blue
 Equalize Bonnet: Green
 Vent Bonnet: Red
 Color Coding as Shown on Diagram to Left

Teflon™ Bonnet Assembly

Standard Materials					
Valve	Body	Bonnet	Stem	Ball	Packing
CS	ASTM A108CS	ASTM A108CS	ASTM A582 303SS	SEE OPTION CODES ON PAGE 4	Teflon™
SC	ASTM A105CS	ASTM A182 316SS	ASTM A182 316SS		
316SS	ASTM A182 316SS	ASTM A182 316SS	ASTM A182 316SS		

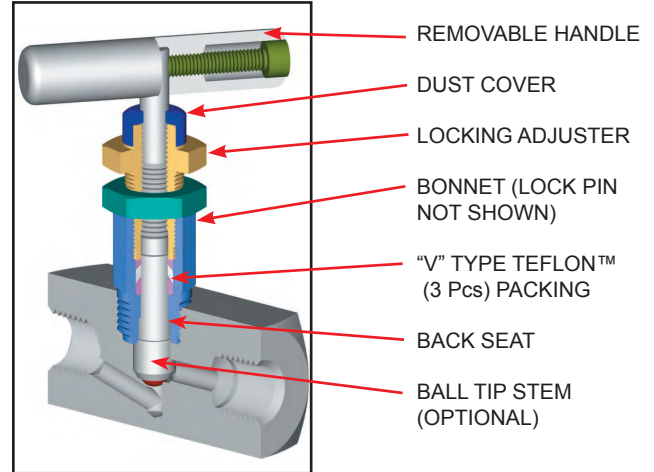

Grafoil™ Bonnet Assembly

Standard Materials					
Valve	Body	Bonnet	Stem	Ball	Packing
CS	ASTM A108CS	ASTM A108CS	ASTM A582 303SS	SEE OPTION CODES ON PAGE 4	Grafoil™
SC	ASTM A105CS	ASTM A182 316SS	ASTM A182 316SS		
316SS	ASTM A182 316SS	ASTM A182 316SS	ASTM A182 316SS		

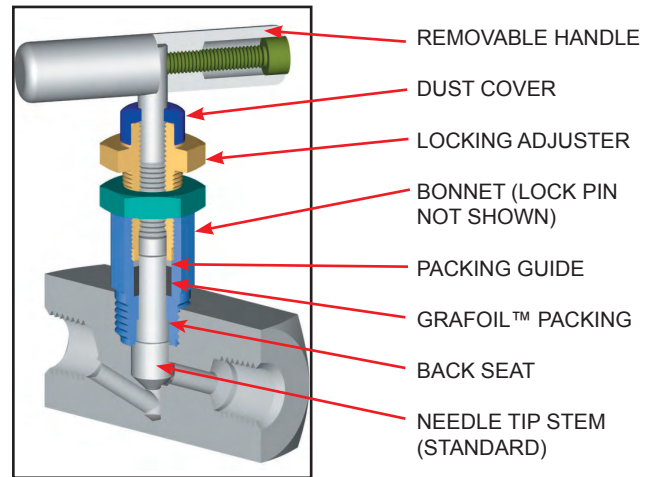

NOTE: Low torque Grafoil™ available (G4 Packing Code)

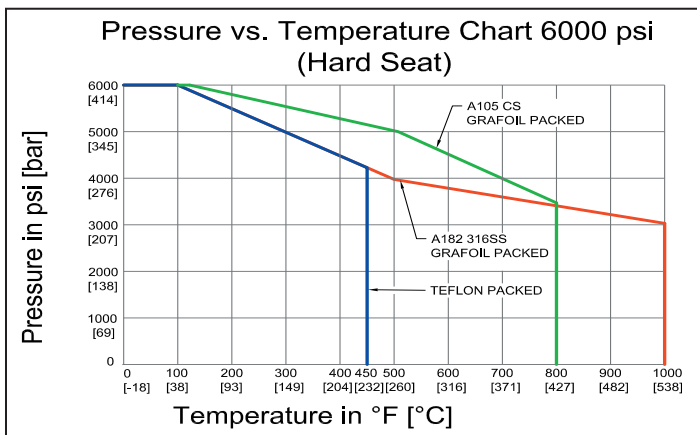

Stem and Seat Configurations

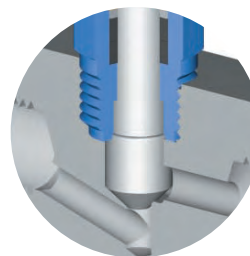

Needle Tip (Standard)

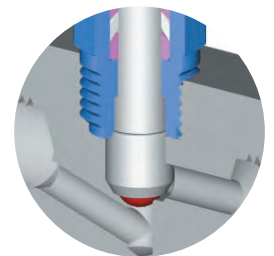

Ball Tip (Optional)

Note: Body material specifications based on ASME B16.34 - 2009. Packing material ratings based on manufacturer's specifications. Approximations only. Phoenix does not represent these values as finite. They are provided only as representative values.

P3MP5H™ 5-Valve Power Style Manifold

Model Numbering System

Phoenix	Orifice Size	Type	Inlet Size	Inlet Type	Outlet Size	Outlet Type	Material	Packing	Seat	Stem Tip
P	3=3/16"	MP5H	8=1/2"	F=FNPT		FL=Flange	SS=ASTM A182 316/316L	T=Teflon™ (PTFE)	Integral (leave blank)	Needle Tip Standard (leave blank)
				FT=Female Tube Fitting			SC=ASTM A105 CS*	G=Grafoil™		B=316SS Ball Tip
				FL=Flange			CS=ASTM A108 CS*	G4=Low Torque Grafoil™		BC=Ceramic Ball Tip
							C5=ASTM A350 LF2			BM=Monel™ Ball Tip
							N4=Monel™ 400			
							N6=Inconel™ 625			
							N8=Inconel™ 825			
							N2=Hastelloy™ C276			
EXAMPLE: P3MP5H8FFLSSTB = 3/16" Orifice, 5-Valve Manifold Power Style, 1/2" FNPT Inlet, Flange Outlet, 316 SS Body, Teflon™ Packing, Integral Seat, 316 SS Ball Tip Stem										
P	3	MP5H	8	F		FL	SS	T		B
*For code applications, A105 CS must be selected for CS valves. Code grade bolts must be specified for code applications. Note: Standard Bolting Options , CS - carbon steel, Gr.8, zinc plated bolts; SS - stainless steel, 18.8 (304SS) bolts.										

Option Codes	Description
LB	Bonnet Lock
CC	Chlorine Clean
OC	Oxygen Clean
TG	SS Tag
SGL	Sour Gas ISO NACE Latest Rev.
N4	Monel™ 400 Stem
N5	Monel™ 500 Stem
N6	Inconel™ 625 Stem
N8	Inconel™ 825 Stem
N2	Hastelloy™ C276 Stem
H(V)MB	Horizontal (Vertical) Mounting Bracket
H(V)MBS	SS Horizontal (Vertical) Mounting Bracket
S6	316 SS Bolts
225CS	2.25" CS Bolts
225S4	2.25" 304 SS Bolts
225S6	2.25" 316 SS Bolts
B7	AlSI 4140/4142 QT
B8C1	Class 1, 304SS, ST
B8MC1	Class 1, 316SS, ST
B8C2	Class 2, 304SS, ST, SH
B8MC2	Class 2, 316SS, ST, SH

Use with Confidence, Phoenix Precision Products Meet the Following Specifications:

- ✓ ASME B31.1 Power Piping
- ✓ ASME B31.3 Process Piping
- ✓ ASME B16.34 Valves - Flanged, Thread, and Welding End
- ✓ API 598 Valve Inspection and Testing
- ✓ MSS SP-25 Standard Marking Systems for Valves, Fittings and Flange Unions
- ✓ MSS SP-99 Instrument Valves
- ✓ MSS SP-105 Instrument Valves for Code Applications
- ✓ NACE MR0175/ISO15156 for all 316SS valves and A105CS body/316SS bonnet (SC-Material Code) when in service with less than 50 PPM of chlorides

Code Bolting Information
1. B7, B8C1, B8MC1, B8C2, B8MC2 are code grades to ASTM A193;
2. To specify code grade bolting, example: 225B7 indicates 2.25" bolt length; B7 grade, alloy steel, AlSI 4140/4142
3. QT-Quenched & Tempered; ST-Carbide Solution Treated; SH-Strain Hardened

Seal and Seat Material Temperature Rating

Code	Description	Min. Temp.	Max. Temp.
T	Teflon™	-65°F (-54°C)	450°F (232°C)
G	Grafoil™ (SS Body)	-70°F (-56°C)	1000°F (537°C)
	Grafoil™ (CS Body)	-70°F (-56°C)	800°F (427°C)
Note: Grafoil™ is suitable for services in excess of 1000°F in a non-oxidizing environment.			

For further information please contact:

Phoenix Precision Ltd.
 2620 21st Street N.E.
 Calgary, Alberta T2E 7L3
 Phone:(403) 291-3154
 Fax: (403) 291-3292
 email: phoenix@phoenixprecision.ca
 www.phoenixprecisionvalves.com



Distributor / Representative:



Phone: +61-3-9872-5822 Fax: +61-3-9872-5129
 E-mail: sales@haldatec.com.au Web Site: www.haldatec.com.au

Phoenix Precision Ltd. (PPL) provides the information herein in good faith but makes no representation as to its comprehensiveness or accuracy. The information contained herein is intended only as a guide to PPL products and services. Individuals using information must exercise independent judgment in evaluating product selection and determining product appropriateness for their particular purpose and system requirements. PPL MAKES NO REPRESENTATIONS OR WARRANTIES, EITHER EXPRESS OR IMPLIED, INCLUDING WITHOUT LIMITATION ANY WARRANTIES OF MERCHANTABILITY OR FITNESS FOR A PARTICULAR PURPOSE WITH RESPECT TO THE INFORMATION SET FORTH HEREIN OR THE PRODUCT(S) TO WHICH THE INFORMATION REFERS. ACCORDINGLY, PPL WILL NOT BE RESPONSIBLE FOR DAMAGES (OF ANY KIND OR NATURE, INCLUDING INCIDENTAL, INDIRECT, OR CONSEQUENTIAL DAMAGES) RESULTING FROM THE USE OF OR RELIANCE UPON THIS INFORMATION. Patents and Patents Pending in the U.S. and foreign countries. PPL reserves the right to change product designs and specifications without notice.

DELTRIN, TEFLON, VITON and TEFLON are registered trademarks (hereinafter referred to as TM) of E.I. Du Pont De Nemours and Company Corporation. PEEK is a registered TM of Whitford Wordwice Company and Whitford B.V. KEL-F is a registered TM of M.W. Kellogg Company. GRAFOIL is a registered TM of High Temperature Materials Inc. and Graftech INC. Corporation. AFLAS is a registered TM of Asahi Glass Co. Ltd. Corporation Japan. MONEL and INCONEL are registered TMs of Huntington Alloys Corporation. HASTELLOY is a registered TM of Haynes International, Inc.

© 2010 by Phoenix Precision Ltd. All rights reserved. Material in this brochure or catalogue may not be reproduced in whole or in part, in any form, without written permission from the publisher.